



TC25 Countertop Gas Fryer

Project _____
 Item _____
 Quantity _____
 CSI Section 11400 _____
 Approval _____
 Date _____

TC25 Countertop Gas Fryer

Models

TC25



TC25
Countertop gas fryer

Standard Features

- Lowest working height (15.75") in a gas countertop fryer
- Millivolt pilot system -- requires no electrical hook-up
- 3/4" NPT gas connection
- Wide cold zone
- Stainless steel frypot, front, door, sides and basket hanger
- Combination gas valve with regulator
- Rack type basket support
- Twin baskets or one full basket

Options & Accessories

- Basket hanger
- Vat cover
- Top connecting strip
- Rack support

Specifications

High-Performance, Low-Profile Fryer Designed For All-Purpose Frying.

DEAN'S low-profile countertop gas fryers are designed for high production frying and sized to permit convenient replacement of low production units. Designed to provide a comfortable working height, this fryer allows uniform integration with other countertop equipment for an attractive, functional kitchen lineup.

The TC25 uses a millivolt pilot system and has a 25-lb. (14 L) oil capacity, a 13.75" x 14" (34.9 x 35 cm) cooking area and uses 72,000 Btuhr. (18,136 kcal) (21 kW) input.

Make the most of your energy dollars with Dean's exclusive Thermo-Tubes with controlled flow tube diffusers. The renowned design allows excellent transfer of heat to the oil for faster, high volume cooking. Less energy goes unused through the vent, resulting in:

- Quick heat-up time.
- Low idle cost per hour during slow periods.
- Low gas consumption per load of product cooked.

Preserve the life of costly oil. Dean's wide cool zone catches crumbs and sediment from the frying area. These particles are trapped in the cold zone where they do not carbonize, contaminate oil or cling to fried foods. The bottom of the frypot is sloped toward the front and is equipped with a 1" (2.54 cm) standard port drain valve.

Assure controlled temperature and rapid recovery. Dean's accurate mechanical thermostat eliminates "loss-time" waiting between loads and requires no electrical hook-up.

Enjoy the peace of mind of Dean fryers and achieve long and dependable life through simplicity of design. Durable stainless steel diffusers and rugged burners keep maintenance to a minimum.



ISO 9001:2000



5489 Campus Drive
Shreveport, LA 71129

Tel: 318-865-1711
Tel: 1-800-221-4583
Fax: 318-868-5987
E-mail: info@dean.enodis.com

<http://dean.enodis.com>
Bulletin No. 830-0004 10/07
Litho in U.S.A. ©Frymaster, LLC

Enodis®



TC25 Countertop Gas Fryer

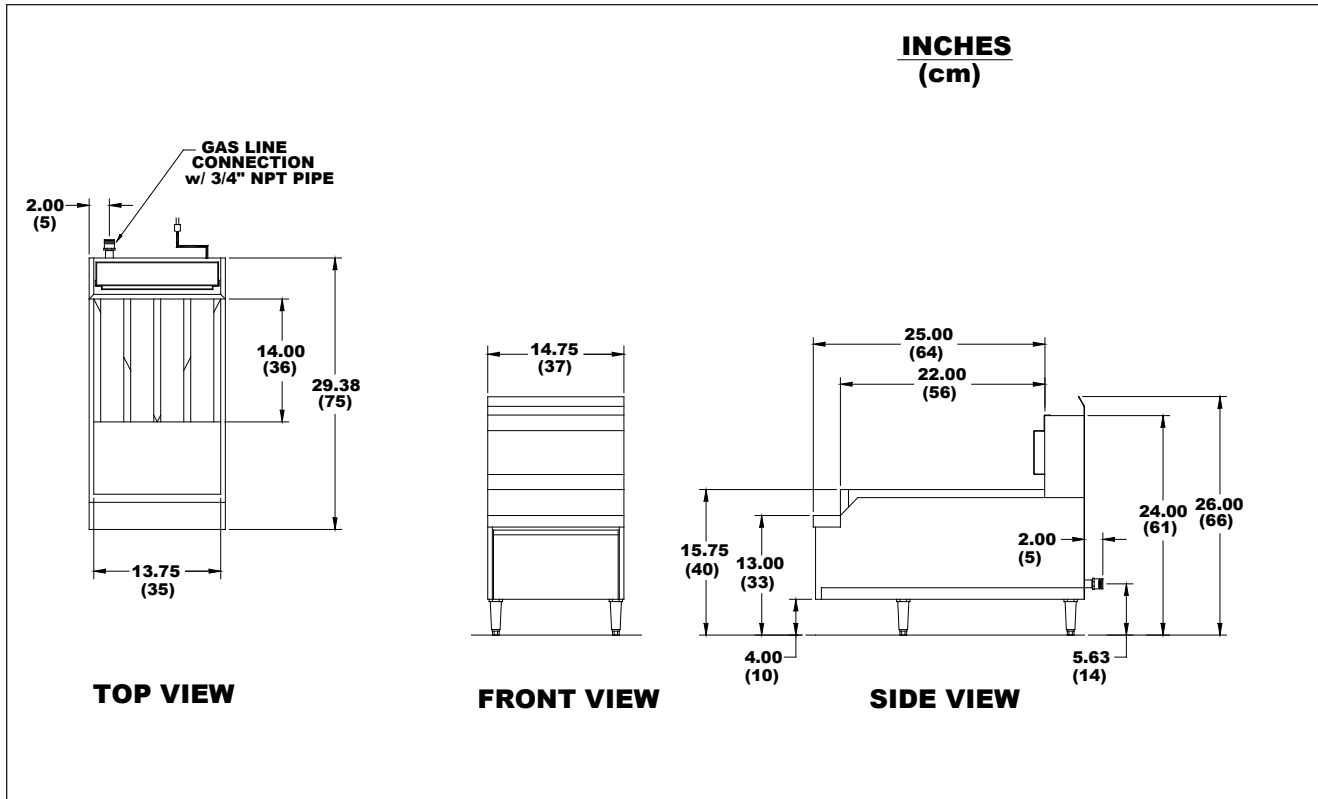

DIMENSIONS

MODEL NO.	SHORTENING CAPACITY	OVERALL SIZE (CM)				DRAIN VALVE (CM)	NO. OF TUBES	FRYING AREA	SHIPPING lbs./cu. ft. (kg/m ³)
		WIDTH	DEPTH	OVERALL HEIGHT	WORK HEIGHT				
TC25	25 lbs. (12 liters)	14.75" (37)	29.38" (75)	24" (61)	15.75" (40)	1" (2.5)	4	13.75" x 14" (34.9 x 35)	140 lbs./15 (63/0,42)

POWER REQUIREMENTS

NATURAL OR LP GAS INPUT RATING	GAS CONNECTION	ELECTRICAL REQUIREMENT
72,000 BTU/hr. (18,136 kCal) (21 kW)	3/4" N.P.T. regulator not required	Millivolt

SHORT TERM SPECIFICATION

Shall be DEAN Model TC25 Dim. 14.75" wide, 25# (14L) oil capacity requiring 72,000 BTU natural or LP gas input (3/4" N.P.T. connection) and mechanical controls..

ORDERING DATA

Please specify:
 Natural or propane gas
 Altitude -- if above 2000 ft. (610 m)

DO NOT CURB MOUNT

Model # _____
 CSI Section 11400 _____

5489 Campus Drive
 Shreveport, LA 71129

Tel: 318-865-1711
 Tel: 1-800-221-4583
 Fax: 318-868-5987
 E-mail: info@dean.enodis.com

<http://dean.enodis.com>
 Bulletin No. 830-0004 10/07
 Litho in U.S.A. ©Frymaster, LLC

Enodis