

Slimline

Spec Sheet No. SL-4

Job Name _____

Item No. _____

Four Compartment Bar Sink

- SLB-44C
- SLB-64C
- SLB-74C
- SLB-84C

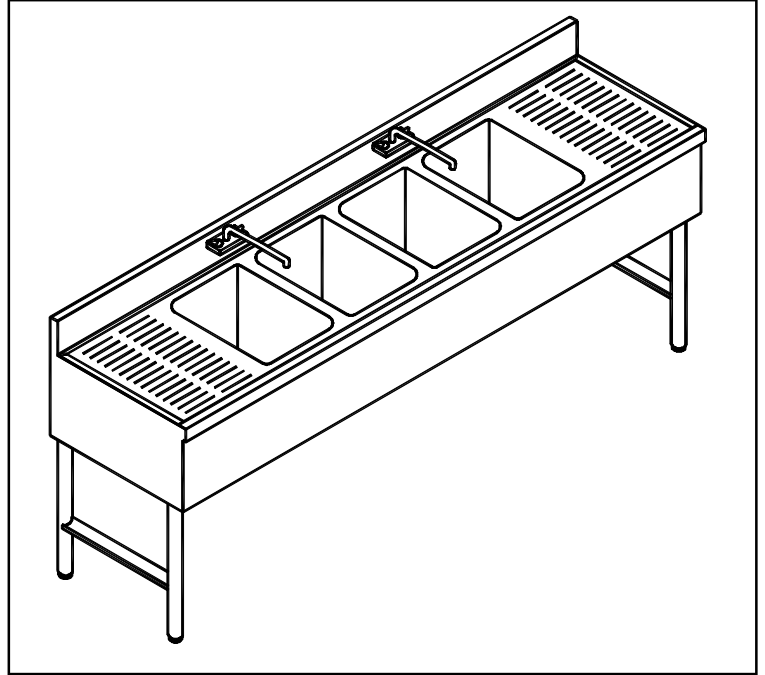

Specifications

•**Sink Bowl:** 14”L x 10”W x 10”D 20 gauge 300 series stainless steel seamless deep drawn.

•**Drainboard:** 20 gauge 300 series stainless steel, embossed and seamless welded to sink bowl.

•**Front Apron:** 22 gauge 300 series stainless steel.

•**Sides:** 20 gauge 430 series stainless steel.

•**Backsplash:** 22 gauge 300 series stainless steel.

•**Under Structure:** 22 gauge galvaneal fronts and backs, 11 gauge electrogalvaneal leg channel.

•**Legs:** 1-5/8” O.D. 18 gauge galvanized with electro static black powder coat and black plastic adjustable bullet feet. To include stainless steel legs add the suffix -SS.(Optional)

•**Plumbing:** 1-1/2” I.P.S. drain.

•**Faucets:** (2) 4” on center splash mount with 8” swivel spout.



Supreme Metal



Slimline

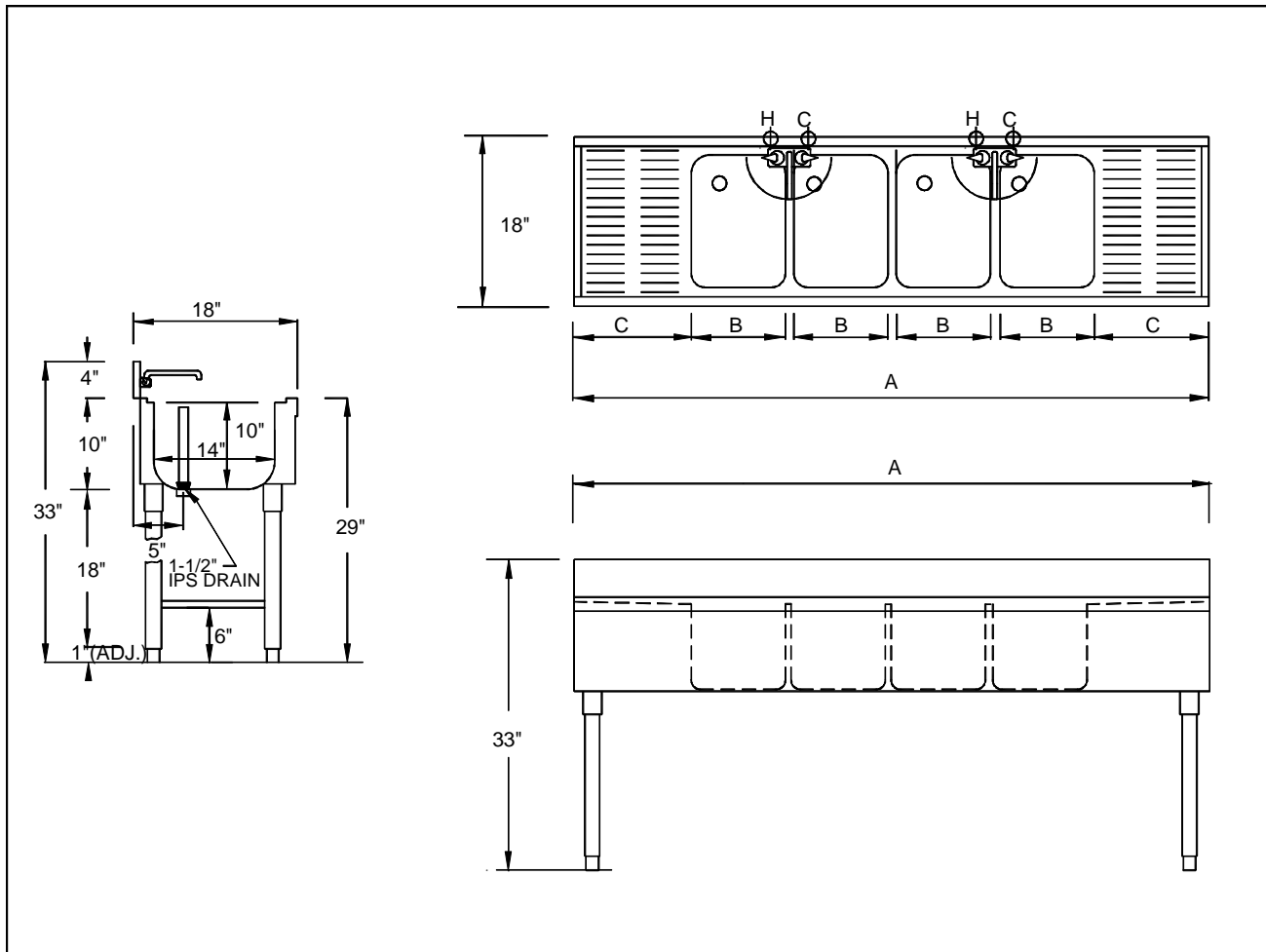

Model Number	Overall Length(A)	No. of Bowls(B)	Drainboard Length(C)	Packaged Weight	Packaged Cubic Feet	Sink Location
SLB-44C	47"	4	N/A	85 LBS.	12.2	Center
SLB-64C	71"	4	12"	88 LBS.	18	Center
SLB-74C	83"	4	18"	94 LBS.	20.9	Center
SLB-84C	95"	4	24"	105 LBS.	23.8	Center

SupremeMetal is constantly engaged in a program of improving their products. We reserve the right to change our specifications without prior notice.