



Item No. \_\_\_\_\_  
 Project \_\_\_\_\_  
 Quantity \_\_\_\_\_

## Electric, Two-Pan Deck [Bake] Ovens

## Model: S[1,2,3]3827B



Model S23827B shown

### PAN & PRODUCTION CAPACITY GUIDE

Capacity/Model:	S13827B*	S23827B	S33827B
18" x 26" Full Sheet	2	4	6
Pies - 9"	12	24	36
Bread - 1 lb. loaves	20	40	60

\* Or the S3827B Model

### SHORT/BID SPECIFICATION

Deck Oven[s] shall be **LANG Manufacturing Model S** [Insert 1, 2 or 3] **3827B**, a 6-kW [each] electric heated two-pan **bake** oven, with: 8" high cooking compartment; full-width, spring loaded pull-down door, with double pane, tempered glass viewing window; all stainless steel exterior; insulated, aluminized steel cooking compartment; one heavy duty pan rack standard; plus all the features listed and options/accessories checked:

### STANDARD PRODUCT WARRANTY

One year, parts & labor

### CONSTRUCTION FEATURES

- Heavy duty 430 Series stainless steel exterior, with attractive No. 4 finish
- Cooking compartment is aluminized steel and fully insulated on six sides
- Heavy duty spring-loaded pull-down door with grab-bar handle
- Double pane tempered glass viewing window
- Recessed, right side mounted control panel
- 27" [S13827B ], 16" [S23827B ] or 6" high [S33827B] legs standard
- One heavy duty chrome plated wire rack

### PERFORMANCE FEATURES

- Top & bottom mounted heating elements enclosed in Incoloy sheathing
- Stackable up to three high, for more capacity in same footprint
- 20" high oven reduces loading height of upper stacked units
- Reinforced oven deck with raised edges eliminates warping
- Sturdy pull-down door serves as loading platform
- 100-450°F operating temperature range

### CONTROL PACKAGE [Per Deck]

- Simple knob-set time and temperature controls
- 3-heat switch for: top only, bottom only or heat from both
- 60 minute timer
- Manual vent rod



Sheet No. LSP-D2 (rev. 9/03)

# Electric, Two-Pan Deck [Bake] Ovens

# Model: S[1,2,3]3827B

## INSTALLATION REQUIREMENTS

- (E) 208V or 240V, 1-Phase or 3-Phase power required; or 480V, 3-Phase as option
- Installation under approved vent hood may be required. Consult local codes. [Power connection[s] from bottom. See below]

## OPTIONS & ACCESSORIES

- 480 Volt, 3-phase model, per oven deck
- 27" stainless steel angular legs for S3827B Model
- 16" stainless steel angular legs for S3827B Model
- 6" stainless steel angular legs for S3827B Model
- Solid stainless steel door [no window], per oven deck
- Extra wire pan racks [one provided as std., per oven deck]

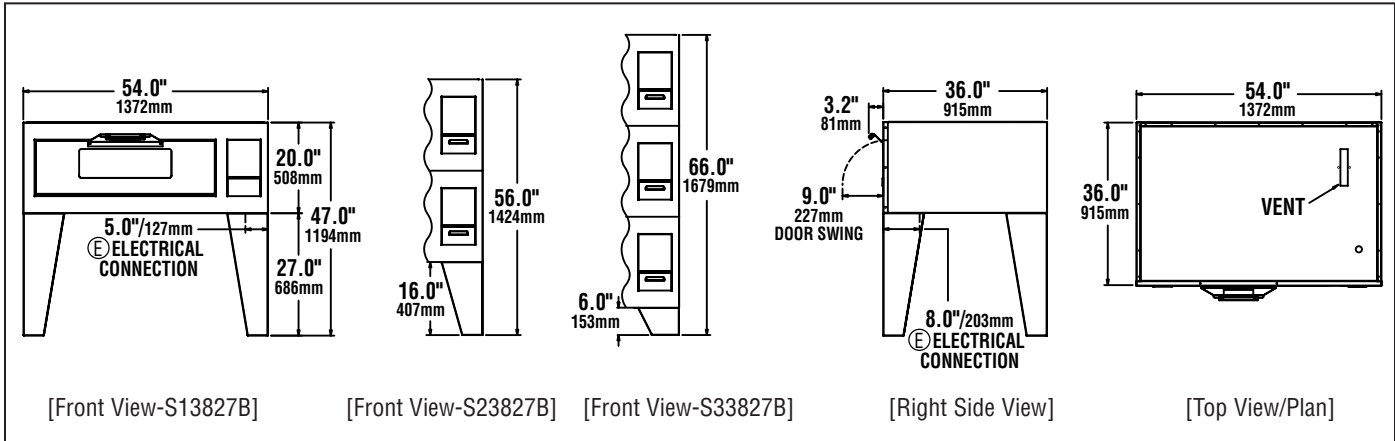

Model	Height x Width x Depth (without legs)		Clearance from combustible surface*	Weight		Freight Class
	External	Inside Oven Dimension		Actual	Shipping	
S13827B	20.0" x 54.0" x 36.0" 508mm x 1372mm x 915mm	8.0" x 38.0" x 30" 203mm x 965mm x 762mm	Sides: 2.0" (51mm) Back: 2.0" (51mm)	390 lbs. 177 kg	430 lbs. 195 kg	70
S23827B	40.0" x 54.0" x 36.0" 1016mm x 1372mm x 915mm	8.0" x 38.0" x 30" 203mm x 965mm x 762mm	Sides: 2.0" (51mm) Back: 2.0" (51mm)	705 lbs. 320 kg	785 lbs. 357 kg	70
S33827B	60.0" x 54.0" x 36.0" 1524mm x 1372mm x 915mm	8.0" x 38.0" x 30" 203mm x 965mm x 762mm	Sides: 2.0" (51mm) Back: 2.0" (51mm)	1045 lbs. 475 kg	1165 lbs. 530 kg	70

\* Noncombustible floor only.

Voltage	(E) Electrical Requirements By Model						
	Phase	Model S1382B		Model S2382B		Model S3382B	
		Total kW	Amps/Line	Total kW	Amps/Line	Total kW	Amps/Line
208V/60Hz	1	6.0	28.8	12.0	57.7	18.0	86.5
240V/60Hz	1	6.0	25.0	12.0	50.0	18.0	75.0
208V/60Hz	3	6.0	28.8	12.0	50.0	18.0	57.7
240V/60Hz	3	6.0	25.0	12.0	43.3	18.0	43.3
408V/60Hz	3	6.0	12.5	12.0	21.7	18.0	21.7

## CAD SYMBOLS & PRICING



Due to continuous improvements, specifications subject to change without notice.



Sheet No. LSP-D2 (rev. 9/03)

**LANG MANUFACTURING COMPANY** • 6500 Merrill Creek Parkway, Everett, WA 98203  
TOLL FREE: 800.882.6368 • FAX: 425.349.2733 • www.langworld.com