



Item No. _____
 Project _____
 Quantity _____

Electric, Two-Pan Deck [Roast] Ovens

Model: S[1,2,3]3827R



Model S33827R shown

PAN & PRODUCTION CAPACITY GUIDE

Capacity/Model:	S13827R*	S23827R	S33827R
18" x 26" Full Sheet	2	4	6
Meat in pounds	125	250	375
Whole turkeys	4	8	12

* Or the S3827R Model

SHORT/BID SPECIFICATION

Deck Oven[s] shall be **LANG Manufacturing Model S**__ [Insert 1, 2 or 3] **3827R**, a 6-kW [each] electric heated two-pan **roast** oven, with: 12" high cooking compartment; full-width, spring loaded pull-down door, with double pane, tempered glass viewing window; all stainless steel exterior; insulated, aluminized steel cooking compartment; one heavy duty pan rack standard; plus all the features listed and options/accessories checked:

STANDARD PRODUCT WARRANTY

One year, parts & labor

CONSTRUCTION FEATURES

- Heavy duty 430 Series stainless steel exterior, with attractive No. 4 finish
- Cooking compartment is aluminized steel and fully insulated on six sides
- Heavy duty spring-loaded pull-down door with grab-bar handle
- Double pane tempered glass viewing window
- Recessed, right side mounted control panel
- 27" [S13827R], 16" [S23827R] or 6" high [S33827R] legs standard
- One heavy duty chrome plated wire rack provided

PERFORMANCE FEATURES

- Top & bottom mounted heating elements enclosed in Incoloy sheathing
- 12" cooking compartment allows roasting of turkeys, beef rounds, etc.
- Stackable up to three high, for more capacity in same footprint
- Reinforced oven deck with raised edges eliminates warping
- Sturdy pull-down door serves as loading platform
- 100-450°F operating temperature range

CONTROL PACKAGE [Per Deck]

- Simple knob-set time and temperature controls
- 3-heat switch for: top only, bottom only or heat from both
- 60 minute timer
- Manual vent rod



Sheet No. **LSP-D3** (rev. 7/03)

Electric, Two-Pan Deck [Roast] Ovens

Model: S[1,2,3]3827R

INSTALLATION REQUIREMENTS

- (E) 208V or 240V, 1-Phase or 3-Phase power required; or 480V, 3-Phase as option
- Installation under approved vent hood may be required. Consult local codes. [Power connection[s] from bottom. See below]

OPTIONS & ACCESSORIES

- 480 Volt, 3-phase model, per oven deck
- 27" stainless steel angular legs for S3827R Model
- 16" stainless steel angular legs for S3827R Model
- 6" stainless steel angular legs for S3827R Model
- Solid stainless steel door [no window], per oven deck
- Extra wire pan racks [one provided as std., per oven deck]

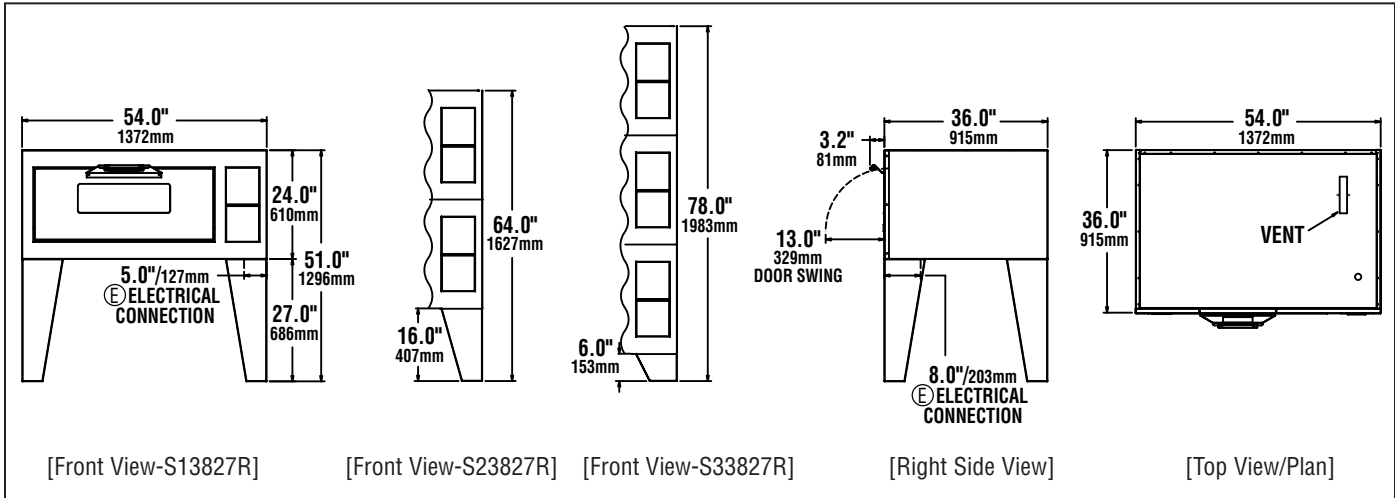

Model	Height x Width x Depth (without legs)		Clearance from combustible surface*	Weight		Freight Class
	External	Inside Oven Dimension		Actual	Shipping	
S13827R	24.0" x 54.0" x 36.0" 610mm x 1372mm x 915mm	12.0" x 38.0" x 30.0" 305mm x 965mm x 762mm	Sides: 2.0" (51mm) Back: 2.0" (51mm)	415 lbs. 189 kg	455 lbs. 207 kg	70
S23827R	48.0" x 54.0" x 36.0" 1219mm x 1372mm x 915mm	12.0" x 38.0" x 30.0" 305mm x 965mm x 762mm	Sides: 2.0" (51mm) Back: 2.0" (51mm)	755 lbs. 343 kg	835 lbs. 380 kg	70
S33827R	72.0" x 54.0" x 36.0" 1829mm x 1372mm x 915mm	12.0" x 38.0" x 30.0" 305mm x 965mm x 762mm	Sides: 2.0" (51mm) Back: 2.0" (51mm)	1120 lbs. 509 kg	1240 lbs. 564 kg	70

* Noncombustible floor only.

Voltage	(E) Electrical Requirements By Model						
	Phase	Model S1382R		Model S2382R		Model S3382R	
		Total kW	Amps/Line	Total kW	Amps/Line	Total kW	Amps/Line
208V/60Hz	1	6.0	28.8	12.0	57.7	18.0	86.5
240V/60Hz	1	6.0	25.0	12.0	50.0	18.0	75.0
208V/60Hz	3	6.0	28.8	12.0	50.0	18.0	57.7
240V/60Hz	3	6.0	25.0	12.0	43.3	18.0	43.3
408V/60Hz	3	6.0	12.5	12.0	21.7	18.0	21.7

CAD SYMBOLS & PRICING



Due to continuous improvements, specifications subject to change without notice.



Sheet No. LSP-D3 (rev. 7/03)

LANG MANUFACTURING COMPANY • 6500 Merrill Creek Parkway, Everett, WA 98203
TOLL FREE: 800.882.6368 • FAX: 425.349.2733 • www.langworld.com