

BARBOSS® ADVANCE

FEATURES

- 6 optimized programs with automatic shut-off

Fully programmable

- XP Container and patented Blade

Pulse control

- Advanced technology motor designed for demanding operations

BARBOSS ADVANCE – with 32 oz. / 0.9 Ltr. polycarbonate/stackable XP Container and Blade – pre-programmed with 6 programs

Motor: 2 HP motor (varies by voltage)

Pack: 1 per standard pack

Weight: 13 lbs. / 5.9 kg

Case Dimensions: 13.1 in. / 33.3 cm High x
11.9 in. / 30.2 cm Wide x
16.9 in. / 42.9 cm Deep

WARRANTY AND SERVICE CONTRACT

In the United States and Canada, the Vita-Mix BarBoss Advance is backed by a three-year warranty against defects in parts and workmanship and includes a one-year service contract. Other warranties apply outside the United States and Canada. Contact your local Vita-Mix Distributor for details or telephone +1.440.782.2450 for a distributor near you.



For more information, contact your local foodservice distributor.

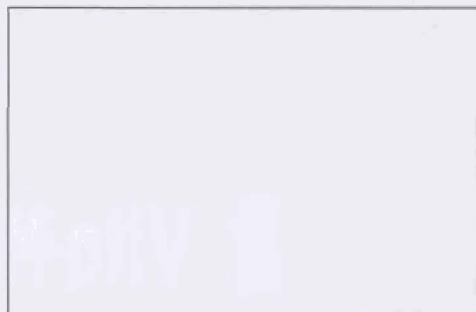

© 2006 Vita-Mix® Corporation 101154 08/06 Printed in U.S.A.

BENEFITS

- Keep customers coming back for your consistently smooth, delicious frozen drinks

Combine the most difficult-to-blend ingredients with ease and speed

- No need to monitor blending – turn it on and walk away

- Optimize blender for your signature bar drinks

Homogenize extra thick ingredients completely for smooth, creamy drinks

- Reduce blending time, increase drink volume and profits

- Quickly refresh drinks

- No overheating during peak volumes or when using extra thick ingredients

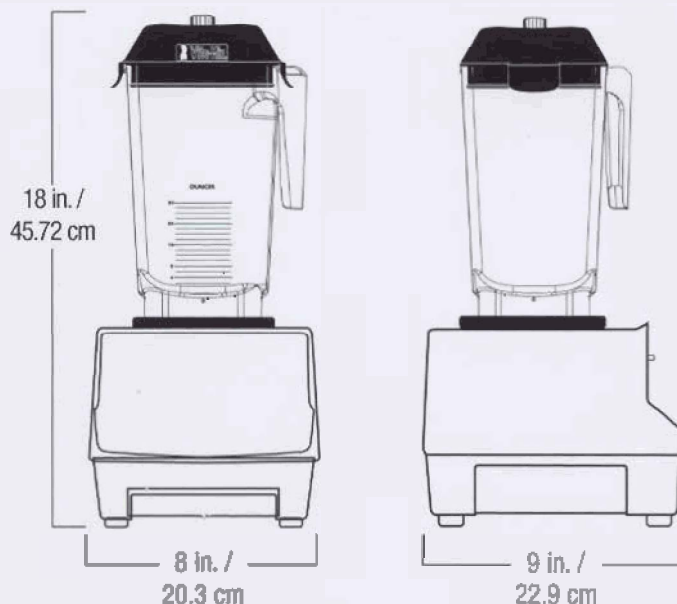

Item # Description

- | | |
|-------|--|
| 5066 | BarBoss Advance, 120V, 50/60 Hz, 11.5 Amps |
| 10121 | BarBoss Advance, 120V EMC, 50/60 Hz, 11.5 Amps |
| 10111 | BarBoss Advance, 100V, 50/60 Hz, 900 Watts |
| 10101 | BarBoss Advance, 220-240V, 50/60 Hz, 750-850 Watts |

www.vitamix.com/foodservice/barboss

800-4DRINK4



FOODSERVICE

For a Dealer near you, contact Vita-Mix:

US, Canada and Latin America: PHONE: 440-235-0214;
FAX: 440-235-9670; EMAIL: foodservice@vitamix.com

For a Distributor in all other countries: TEL: +1.440.782.2450;
FAX: +1.440.782.2220; EMAIL: international@vitamix.com