



**TRUE FOOD SERVICE EQUIPMENT, INC.**

2001 East Terra Lane • P.O. Box 970 • O'Fallon, Missouri 63366  
 (636)240-2400 • FAX (636)272-2408 • (800)325-6152 • www.truemfg.com  
 Parts Dept. (800)424-TRUE • Parts Dept. FAX# (636)272-9471

Project Name: \_\_\_\_\_

A/A #

Location: \_\_\_\_\_

Item #: \_\_\_\_\_ Qty: \_\_\_\_\_

SIS #

Model #: \_\_\_\_\_

Model:  
**GDM-12FC**

**Glass Door Merchandiser:**  
*Floral Case*



**GDM-12FC**

- ▶ The world's #1 manufacturer of glass door merchandisers.
  - ▶ Oversized and balanced refrigeration system, factory sealed and pre-lubricated for long life. Designed to accommodate a broad range of floral temperature settings, holds 35°F (1.6°C).
  - ▶ Exterior - non-peel or chip black laminated vinyl; durable and permanent.
  - ▶ Interior - attractive, NSF approved, black aluminum interior liner with 300 series stainless steel floor.
  - ▶ Self closing door. Positive seal, torsion type closure system.
  - ▶ "Low-E", double pane thermal glass door assembly with extruded aluminum frame. The latest in energy efficient technology.
  - ▶ Adjustable, heavy duty black PVC coated shelves.
  - ▶ Special interior agro lighting designed for flowers to prevent premature discoloration.
  - ▶ Door sign decal.
  - ▶ Entire cabinet structure is foamed-in-place using high density, CFC free, polyurethane insulation.
- Bottom mounted units feature**
- ▶ "No stoop" lower shelf to maximize product visibility.
  - ▶ Storage on top of cabinet.
  - ▶ Easily accessible condenser coil for cleaning.

**ROUGH-IN DATA**

Specifications subject to change without notice.  
 Chart dimensions rounded up to the nearest 1/8" (millimeters rounded up to next whole number).

Model	Door	Capacity (Cu. Ft.) (liters)	Shelves	Cabinet Dimensions (inches) (mm)			HP	Voltage	Amps	NEMA Config.	Cord Length (total ft.) (total m)	Crated Weight (lbs.) (kg)
				L	D <sup>†</sup>	H						
GDM-12FC	1	12 340	2	24 <sup>7</sup> / <sub>8</sub> 632	23 <sup>1</sup> / <sub>8</sub> 588	62 <sup>3</sup> / <sub>8</sub> 1585	1/5 1/4	115/60/1 230-240/50/1	5.0 3.0	5-15P ▲	9 2.74	233 106

<sup>†</sup> Depth does not include 1<sup>3</sup>/<sub>8</sub>" (35 mm) for door handle.

▲ Plug type varies by country.

4/06 Printed in U.S.A.

**APPROVALS:**

**AVAILABLE AT:**

Model:  
**GDM-12FC**

**Glass Door Merchandiser:**  
*Floral Case*



**STANDARD FEATURES**

**DESIGN**

- True's commitment to using the highest quality materials and refrigeration systems provides the user with better product temperatures, and lower utility costs in an attractive merchandiser that brilliantly displays high profit floral arrangements.
- True's floral merchandisers offer interior agro lighting combined with a baffled airflow design which creates the ideal environment to prolong fresh flower shelf life.
- Brilliant black exterior and interior with product accentuating black shelves further entice customers to purchase high profit floral arrangements.

**REFRIGERATION SYSTEM**

- Factory engineered, self-contained, capillary tube system using environmentally friendly (CFC free) 134A refrigerant.
- Oversized and balanced refrigeration system, factory sealed and pre-lubricated for long life. Designed to accommodate a broad range of floral temperature settings, holds 35°F (1.6°C).
- Sealed, cast iron, self-lubricating evaporator fan motor(s) and larger fan blades give True merchandisers a more efficient low velocity, high volume airflow design.
- Baffled airflow provides even air distribution for longer shelf life of fresh flowers.
- Bottom mounted condensing unit positioned for easy maintenance; "No stoop" lower shelf maximizes visibility by raising merchandised product to higher level.

**CABINET CONSTRUCTION**

- Exterior - non-peel or chip black laminated vinyl; durable and permanent.
- Interior - attractive, NSF approved, black aluminum interior liner with 300 series stainless steel floor.
- Insulation - entire cabinet structure is foamed-in-place using high density, CFC free, polyurethane insulation.
- Welded, heavy duty galvanized frame rail dipped in rust inhibiting enamel paint for corrosion protection inside and out.
- Frame rail fitted with leg levelers.
- Door sign decal.

**DOOR**

- "Low-E", double pane thermal glass door assembly with extruded aluminum frame. The latest in energy efficient technology.
- Door fitted with 15" (381 mm) long black PVC handle.
- Self closing door. Positive seal, torsion type closure system.
- Magnetic door gasket of one piece construction, removable without tools for ease of cleaning.

**SHELVING**

- Two (2) adjustable, heavy duty, black PVC coated wire shelves 20<sup>5</sup>/<sub>8</sub>" L x 17<sup>1</sup>/<sub>2</sub>" D (524 mm x 445 mm). Four (4) chrome plated shelf clips included per shelf.
- Shelf support pilasters made of same material as cabinet interior; shelves are adjustable on 1/2" (13 mm) increments.

**LIGHTING**

- Fluorescent interior lighting. Safety shielded.
- Special interior agro lighting designed for flowers to prevent premature discoloration.

- Cabinet lighting utilizes electronic ballast and T-8 bulbs for brighter illumination, longer bulb life and increased energy efficiency.

**MODEL FEATURES**

- Evaporator is epoxy coated to eliminate the potential of corrosion.

**ELECTRICAL**

- Unit completely pre-wired at factory and ready for final connection to a 115/60/1 phase - 15 amp dedicated outlet. Cord and plug set included.



115/60/1  
NEMA-5-15R

**OPTIONAL FEATURES/ACCESSORIES**

Upcharge and lead times may apply.

- 230-240V / 50 Hz.
- White exterior.
- Rosewood exterior.
- Mirrored back.
- 2 1/2" (64 mm) diameter castors.
- Barrel lock (factory installed).
- White wire shelves.
- Remote cabinets (condensing unit supplied by others; system comes standard with 404A expansion valve and requires R404A refrigerant). Consult factory technical service department for BTU information.

**PLAN VIEW**

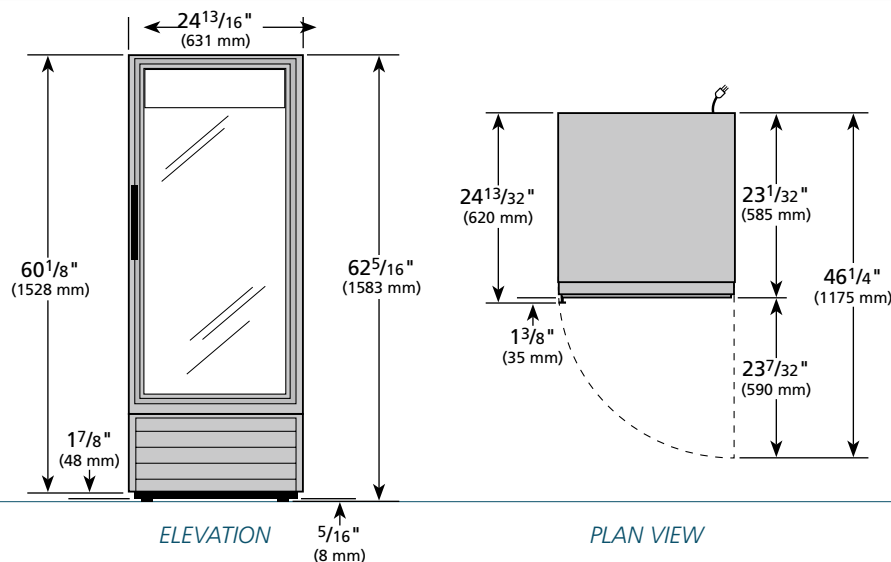

**WARRANTY**  
One year warranty on all parts and labor and an additional 4 year warranty on compressor. (U.S.A. only)

METRIC DIMENSIONS ROUNDED UP TO THE NEAREST WHOLE MILLIMETER  
SPECIFICATIONS SUBJECT TO CHANGE WITHOUT NOTICE

	Model	Elevation	Right	Plan	3D
	GDM-12FC	TFAY55E	TFAY55S	TFAY55P	TFAY553

**TRUE FOOD SERVICE EQUIPMENT**