



TRUE FOOD SERVICE EQUIPMENT, INC.

2001 East Terra Lane • P.O. Box 970 • O'Fallon, Missouri 63366
 (636)240-2400 • Fax (636)272-2408 • (800)325-6152 • Intl Fax# (001)636-272-7546
 Parts Dept. (800)424-TRUE • Parts Dept. Fax# (636)272-9471 • www.truemfg.com

Project Name: _____

A/A #

Location: _____

Item #: _____ Qty: _____

SIS #

Model #: _____

Model:
TSID-48-4-L

Display Case:
Low-Height Single Duty Deli Case



TSID-48-4-L

- ▶ True's commitment to using the highest quality materials and oversized refrigeration systems provides the user with colder product temperatures, and lower utility costs in an attractive self-service display.
- ▶ Cabinet is NSF-7 certified to hold open food product.
- ▶ Oversized, factory balanced, refrigeration system holds 38°F to 40°F (3.3°C to 4.4°C). Gravity coil refrigeration system provides high humidity environment for exceptional preservation of meats and deli products.
- ▶ "Low-E", double pane thermal glass front and rear self-closing doors provide maximum insulation value for greater efficiency and energy savings.
- ▶ Exterior - non-peel or chip white laminated vinyl; durable and permanent.
- ▶ Interior - attractive, NSF approved, white aluminum liner. 300 series stainless steel floor with coved corners.
- ▶ Entire cabinet structure is foamed-in-place using high density, CFC free, polyurethane insulation.
- ▶ Case is equipped with front and rear light sources for maximum product display. Fluorescent lamps are low UV emitting to enhance product appearance and increase shelf life.
- ▶ Automatic defrost system; time-initiated, time-terminated.

ROUGH-IN DATA

Specifications subject to change without notice.

Chart dimensions rounded up to the nearest 1/8" (millimeters rounded up to next whole number).

Model	Doors	Capacity (Cu. Ft.) (liters)	Shelves	Cabinet Dimensions (inches) (mm)			HP	Voltage	Amps	NEMA Config.	Cord Length (total ft.) (total m)	Crated Weight (lbs.) (kg)
				L	D†	H						
TSID-48-4-L	4	17 482	1	48 ^{5/8} 1236	32 ^{1/8} 816	42 1067	1/3	115/60/1	8.2	5-15P	9 2.74	405 184

† Depth does not include 5/8" (16 mm) for rear door handles.

3/07 Printed in U.S.A.

APPROVALS:

AVAILABLE AT:

Model:

TSID-48-4-L

Display Case:

Low-Height Single Duty Deli Case



STANDARD FEATURES

DESIGN

- True's commitment to using the highest quality materials and oversized refrigeration systems provides the user with colder product temperatures, and lower utility costs in an attractive self-service display case that brilliantly displays deli meats and cheeses.

REFRIGERATION SYSTEM

- Factory engineered, self-contained, capillary tube system using environmentally friendly (CFC free) 134A refrigerant.
- Gravity coil refrigeration system provides high humidity environment for exceptional preservation of meats and deli products.
- Extra large evaporator coil balanced with higher horsepower compressor and large condenser; maintains cabinet temperatures of 38°F to 40°F (3.3°C to 4.4°C).
- Automatic defrost system; time-initiated, time-terminated.
- Condensing unit located behind grill in back of unit. Entire system slides out for easy cleaning and maintenance.

CABINET CONSTRUCTION

- Exterior - non-peel or chip laminated vinyl; white sides with black front and back grills.
- Stainless steel counter top provides surface for equipment such as registers and point-of-purchase novelties.
- Interior - attractive, NSF approved, white aluminum liner. 300 series stainless steel floor with coved corner.

- Insulation - entire cabinet structure is foamed-in-place using high density, CFC free, polyurethane insulation.
- Welded, heavy duty galvanized frame rail dipped in rust inhibiting enamel paint for corrosion protection inside and out.
- Frame rail fitted with leg levelers.

DOORS

- Front and rear door assemblies feature "Low-E", double pane thermal glass. The latest in energy efficient technology.
- Each door fitted with 12" (305 mm) long handle.
- Self-closing doors. Sliding doors ride on stainless steel V-Channel with stainless steel bearings for smooth, even, positive closure. Doors fit within plastic channel frame.
- Front glass slanted 12° to minimize reflection from overhead lighting enhances your product presentation.

SHELVING

- One (1) adjustable, heavy duty PVC coated wire shelf 43³/₄" L x 22" D (1112 mm x 559 mm). Four (4) chrome plated shelf clips included per shelf.
- Aluminum shelf support pilasters. Shelves are adjustable on 1/2" (13 mm) increments.

LIGHTING

- Case is equipped with front and rear light sources for maximum product display. Fluorescent lamps are low UV emitting to enhance product appearance and increase shelf life.

- Cabinet lighting utilizes electronic ballast and T-8 bulbs for brighter illumination, longer bulb life and increased energy efficiency. Lamps are safety shielded.

MODEL FEATURES

- Evaporator is epoxy coated to eliminate the potential of corrosion.
- NSF-7 compliant for open food product.

ELECTRICAL

- Unit completely pre-wired at factory and ready for final connection to a 115/60/1 phase - 15 amp dedicated outlet. Cord and plug set included.



115/60/1
NEMA-5-15R

OPTIONAL FEATURES/ACCESSORIES

Upcharge and lead times may apply.

- 6" (153 mm) standard legs.
- 6" (153 mm) seismic/flanged legs.
- 2 1/2" (64 mm) diameter castors.
- 4" (102 mm) diameter castors.
- Ratchet lock (requires 2).
- Additional shelves.
- Remote cabinets (condensing unit supplied by others; system comes standard with 404A expansion valve and requires R404A refrigerant.), consult factory technical service department for BTU information.

PLAN VIEW

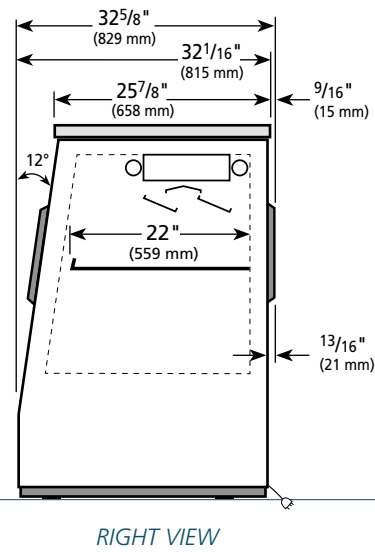
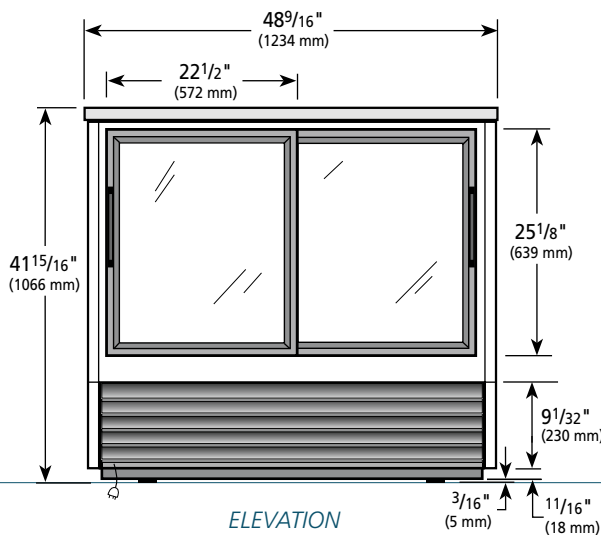

WARRANTY

One year warranty on all parts and labor and an additional 4 year warranty on compressor. (U.S.A. only)

METRIC DIMENSIONS ROUNDED UP TO THE NEAREST WHOLE MILLIMETER

SPECIFICATIONS SUBJECT TO CHANGE WITHOUT NOTICE



Model	Elevation	Right	Plan	3D
TSID-48-4-L	TFQY51E	TFQZ51S	TFQZ51P	TFQZ513

TRUE FOOD SERVICE EQUIPMENT